

PENTA-STAR XP

SELF CANCELING TURN SIGNAL SYSTEM + **RUNNING LIGHTS!**

INSTALLATION INSTRUCTIONS

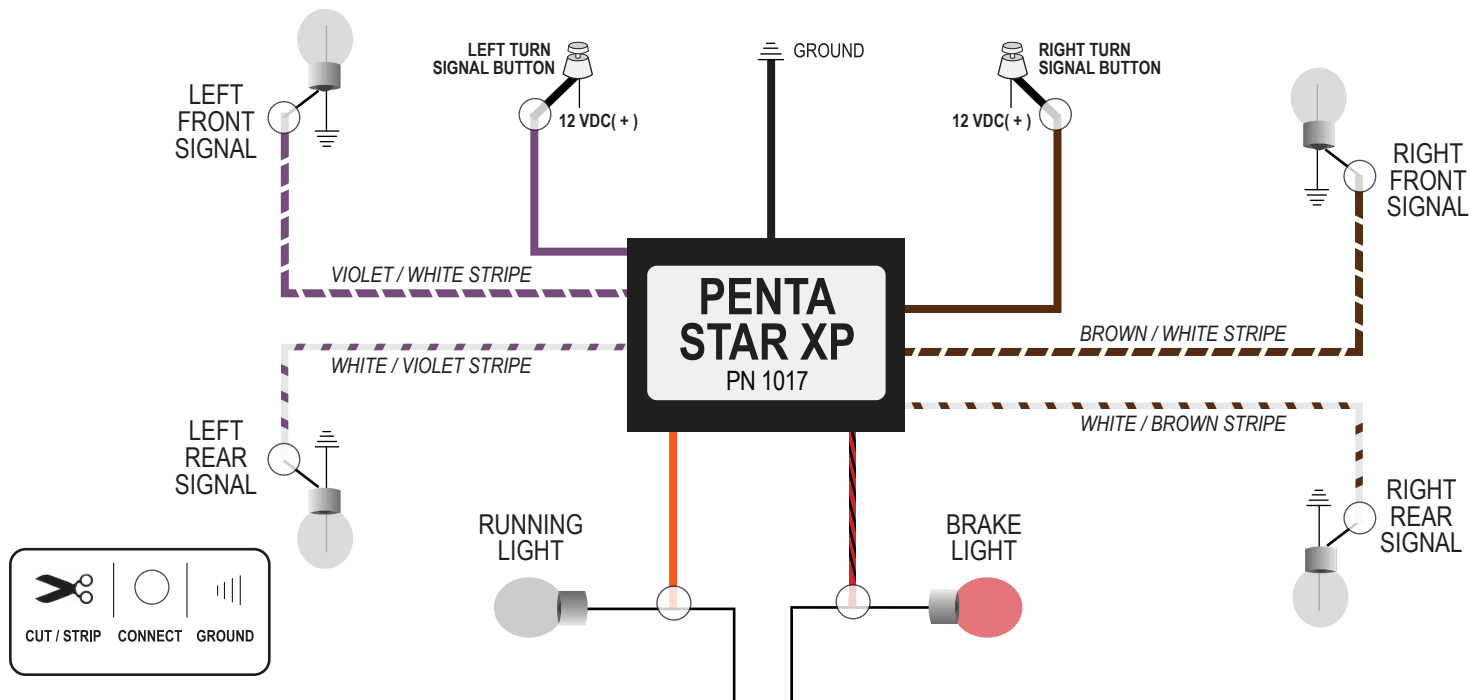

Follow Diagram above for installation.

1. Be sure before you begin installation that your signals are properly functioning to ensure proper modulating after installation.
2. Cut wire / strip 1/4" insulation and connect existing wire with proper means (solder or durable crimp connectors) to color coded module wires.

Hardware Requirements: Two independent momentary turn signal switches are required. The module will not work with latching type toggle switches most commonly found on Japanese motorcycles. (Example; Yamaha, Suzuki, etc.) Any type momentary switch will work with this unit. When wiring a momentary switch **12 VDC power is required** to be wired to the switch.

Circuit Protection: It is highly recommended that the turn signal circuit be protected with a 10 amp fuse or circuit breaker in the power supply lead (orange wire).

Mounting: It is recommended that the module be mounted in a location **not** subject to extreme heat conditions or near high powered electrical areas such as your alternator. It can be mounted with the included double sided adhesive tape.

TURN SIGNAL MODES OF OPERATION

Mode 1 : Press turn signal button for 1 second or less, turn signal lights will flash for 7 seconds, then self cancel. This mode is usually used when changing lanes.

Mode 2 : Press turn signal button for 2-3 seconds, turn signal lights will flash for 20 seconds, then self-cancel. This mode is usually used when slowing down to go around a corner.

Mode 3 : Press turn signal button for 4 seconds or more, turn signal lights will flash for 75 seconds, then self-cancel. This mode is usually used when stopping at a signal light and turn will be made after stopping.

Note: All three modes above can be cancelled by pressing the same turn signal button a second time.

Mode 4 : Hazard Mode - is available all the time and will flash until cancelled. To engage, press both the left and right turn signal buttons for 1 second. To cancel, press both buttons again for one second.

Mode 5 : Brake Lights - Applying the brakes will cause the rear Turn Signals to light as long as the brakes are held. If a turn signal is sent to the rear lights at the same time it will have priority over the brake lights and cause the corresponding light to flash. When the turn signal is canceled the brake light will resume.